

Pneumatic Conveying Systems

SINGLE SOURCE
CUSTOM ENGINEERING
APPLICATION EXPERTISE

VAC-U-MAX

DELIVERING MORE

GLOBAL SERVICE & SUPPORT
100% GUARANTEED
SINCE 1954



Corporate Profile

VAC-U-MAX specializes in design and manufacture of pneumatic systems and support equipment for conveying, weighing and batching of dry materials. The primary technology for conveying is vacuum, but positive pressure pneumatic systems as well as mechanical conveyors are used as applications dictate. An equally important activity is design and manufacture of heavy duty industrial vacuum cleaners, ranging from small air and electric powered drum styled units to large electric and diesel powered units.

Markets Served

VAC-U-MAX equipment and systems are sold worldwide. Major markets for conveying systems include the chemical, food and pharmaceutical industries. Specialty applications include conveying of small parts and objects, including coins and heavy metal powders.

Technologies

A pioneer in vacuum pneumatic conveying, VAC-U-MAX has had many firsts, including air-powered venturi power units, direct-loading of vacuum-tolerant process equipment and vertical-wall "Tube Hopper" material receivers. A UL-listed designer and manufacturer of control panels, VAC-U-MAX furnishes integrated control systems that provide coordination of material movement, batching, and processing, with tie in capabilities to existing control systems.

Technical Services

After consultation with a customer to arrive at system design and equipment specifications, customer's materials can be tested for flow characteristics and other qualities under simulated conditions in the company's well-equipped test laboratory. Equipment designs are rendered on CAD. Drawings can be provided on Disk. Complete installation, startup, operator training and follow-up support are offered.

Major Products

Pneumatic Conveying Systems

- Dilute Phase Vacuum Conveying Systems
- Dense Phase Vacuum Conveying Systems
- Dilute Phase Positive Pressure Conveying Systems
- Dense Phase Positive Pressure Systems
- Multi-ingredient Handling
- Batch Weighing Systems
- Bulk Bag Unloading
- Bulk Bag Loading
- Bag Dump Stations
- Vacuum Conveyors
- Gravity Diverter Valves





The Test Lab

In the VAC-U-MAX Test Lab we have the ability to set virtually any system. From Simple up and in system to demonstrating a batch weigh system VAC-U-MAX can show you how vacuum conveying can help your process and help your company save money. We have tested thousands of materials.



Let us Test your product



With over 3,000 square feet of available floor space, VAC-U-MAX has the ability to create a multitude of equipment configurations. In our forty year's of existence, we have tested thousands of difficult to convey materials, all at no charge to the potential customer.

The facility is fully equipped to meet most customer demands. The lab can conduct a plethora of vacuum conveying tests, as well as demonstrate Aerocon's extensive line of aeromechanical conveyors. We also have a full line of industrial vacuums to test various cleaning applications.

Typically, after a customer meets with a company representative to determine what type of equipment will best suit his applications needs, a product sample is provided. VAC-U-MAX will try to closely duplicate actual conditions of the customer's site.

Whether an application calls for a bulk bag unloader, bag dump stations, microprocessor controlled batch weighing systems, or precise batching of small quantities of multiple ingredients in varying recipe, the test lab can meet your demands.

Vacuum Convey Systems

VAC-U-MAX Basic Vacuum Convey Systems consist of a Single Pick-Up Point, a Single Vacuum Receiver and Vacuum Producers and a control panel. Available in USDA sanitary design they are suitable for the Food, Pharmaceutical and Chemical industries. Distances conveyed vary from 10' "up and in" to 100'. Application include loading a mixer, packaging machine, tablet press, volumetric or gravimetric feeders or any other application where bulk dry powders are conveyed to the process. These save injury costs by eliminating the need for heavy lifting, scooping and climbing.

Single "Up and In" Packaged Conveyor System

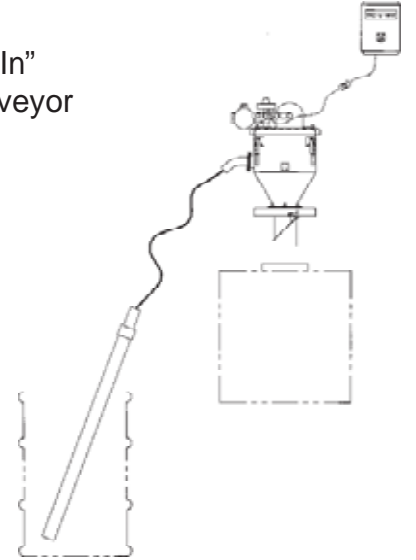

Tube Hopper Vacuum Receiver with Multi-Filter discharging to a Volumetric feeder

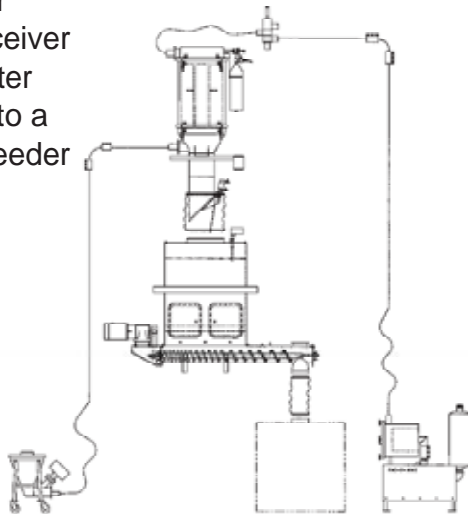

Self Contained Complete Convey System

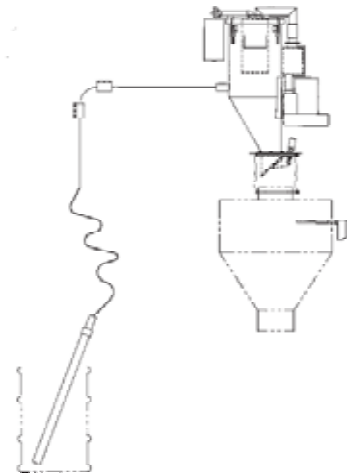

Tube Hopper Receiver with Large Area Filter Housing and full opening discharge valve

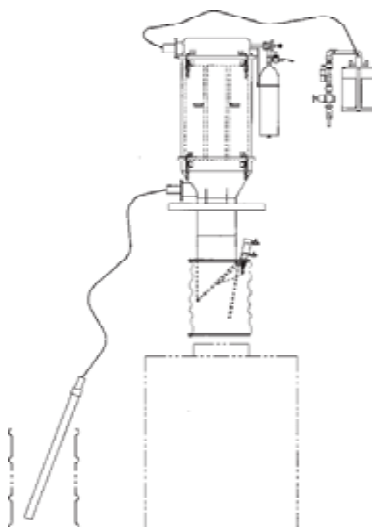



Mobile Conveying Systems

VAC-U-MAX mobile conveyors are furnished with lift frames to accommodate varying discharge heights. Units are easily rolled to and positioned at the desired discharge point. Material can be drawn from a container, a feedbin or a pickup adapter under a bin or process vessel.

VAC-U-MAX Mobile Vacuum Conveying System will convey up to up to 5000 pounds per hour of powders and granules. System is complete with Rolling Frame that can lift the vacuum receiver to a height of at least 91" at the discharge point, Vacuum receiver with replaceable inlet assembly, easy access filter with pulse filter cleaning and full opening discharge valve. Vacuum power sources include Venturi Power Package, Regenerative Blower Package or Positive Displacement Vacuum Pump Package. Mounted on the rolling frame is a control panel to handle the convey, discharge and filter clean functions of the system. USDA Accepted Design.

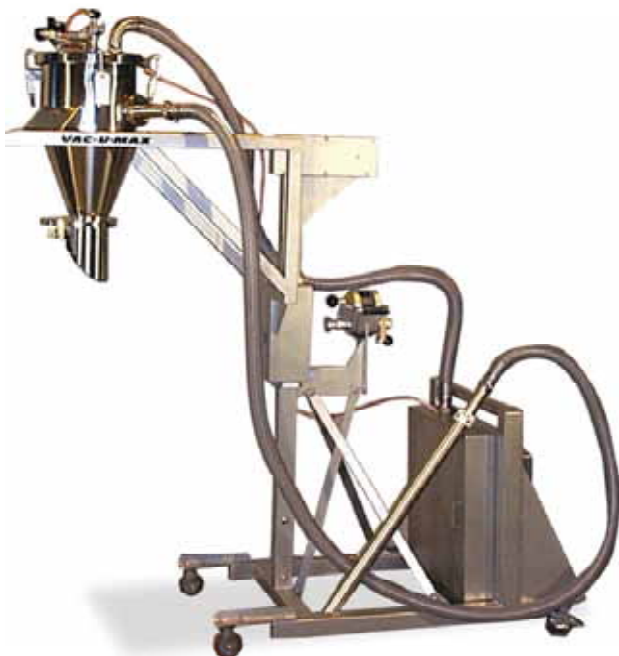

Mobile Convey System with Dual Discharge Outlet

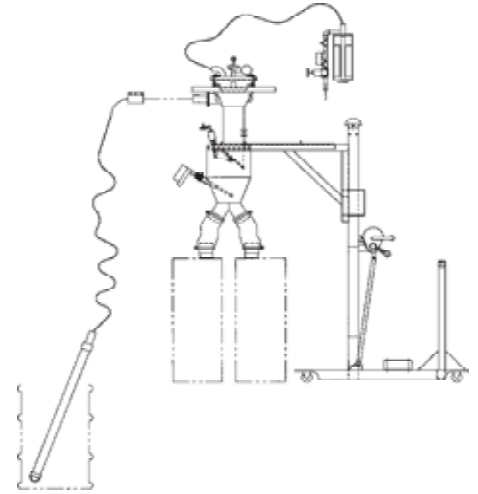

Mobile Convey System with feedbin as the pick point

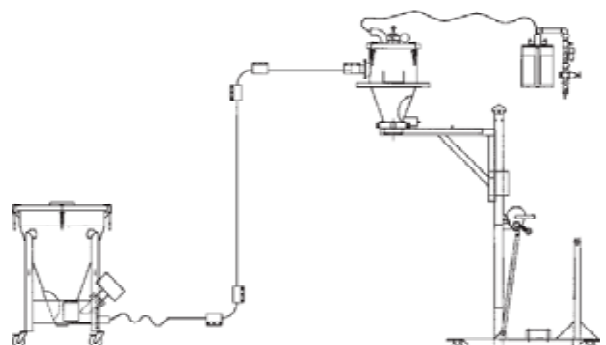



Direct Charge Blender Loading Systems

The principle of vacuum transfer has been proven to be a "better way" to move many types of material and a giant step over manual handling. The technology exists for moving virtually any material that can be pulled through a hose or tube.

A unique adaptation of vacuum transfer is "direct charge blender loading," when a vacuum tight process vessel becomes the primary vacuum receiver for material being charged into it.



Direct Charge loading of "V" Blender using a positive displacement vacuum pump

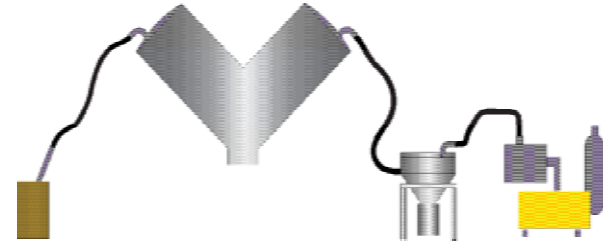

Direct Charge loading of product into "V" type blender using air operated power source and remote filter

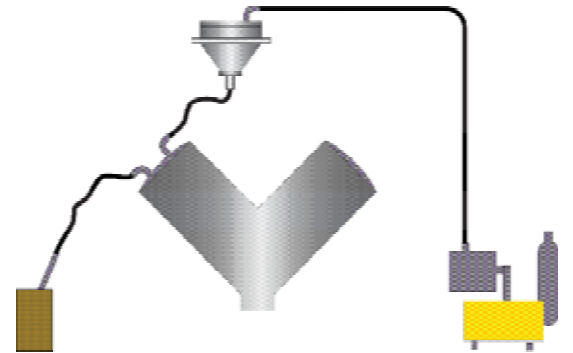

Direct Charge loading of product into "V" type blender using air operated power source and remote filter

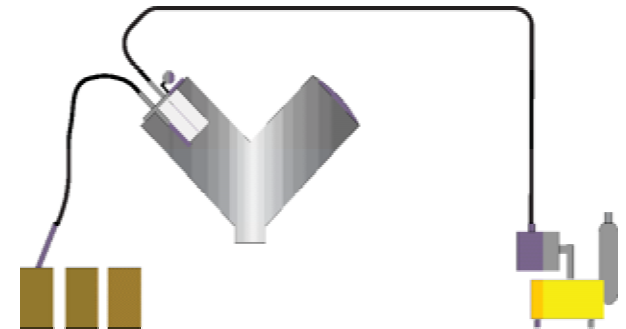

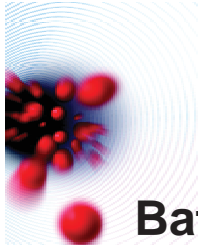

Batch Weighing Systems

Accuracy! VAC-U-MAX guarantees the highest accuracy at .5% of full batch weight

Reliable consistency all the time

Intelligent ingredient management

Automatic batch counting and weighing of material

Computerized keyboard or touch screen entry of all functions: set points, feed rates and calibration

Operator initiated cycling of system with alternate tie into computer control for programmed discharging.

Control system can be located in remote area of plant away from production machinery

VAC-U-MAX weighing systems can be configured to control a wide range of batch weighing receivers and other process vessels.

Computer and printer interface to report a variety of functions from date, operator ID, batch weight, formulation, sequence number and much more.

Stored Recipes.

1. Single Vacuum Receiver Batch Weigh System. Operator Manually selects weight in control panel and prompts system to discharge.

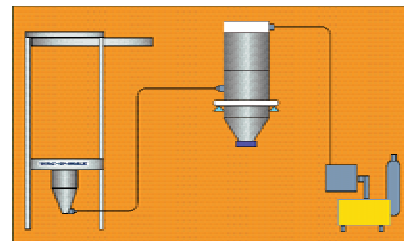

2. Multiple Receiver Batch Weigh System. System can be manually operated or automated through a PLC

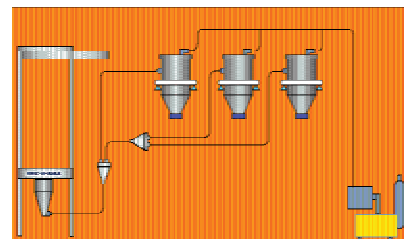

3. Multi Ingredient Handling System. Convey drum drums, bulk bags and silos. Control Panel is pre-programmed with pre-set recipes or operator manually selects weights for each ingredient.

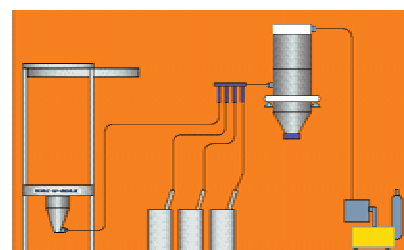

4. Loss-In-Weight Batch Weigh System. Bulk Bag Unloader is on load cells. Material is discharged in the convey tubing with a VAC-U-MAX Screw Discharger for delivery of product to vacuum receiver.

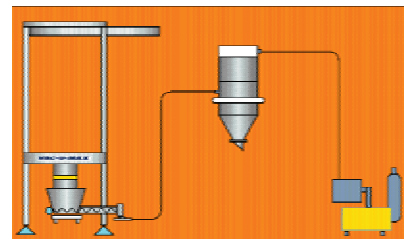

5. Loss-In-Weight Batch Weigh System. Material is conveyed to the vacuum receiver in a Gain-In-Weight mode. When vacuum receiver has achieved desired weight the mode will change to Loss-In-Weight and the Screw Discharger on the vacuum receiver will meter the desired amount of material into the process below.

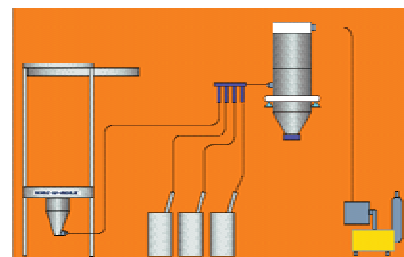



Multi-Ingredient Handling Systems

VAC-U-MAX Multi-Ingredient Handling Systems are designed around the parameters of the process. Systems involve complex controls and very often involve weighing of the material at the pick up point for a Loss-In-Weight transfer or at the discharge end of the system for a Gain-In-Weight transfer. These systems have proven effective when the highest quality assurance of final product is needed.



Sika Corporation, Lyndhurst, NJ

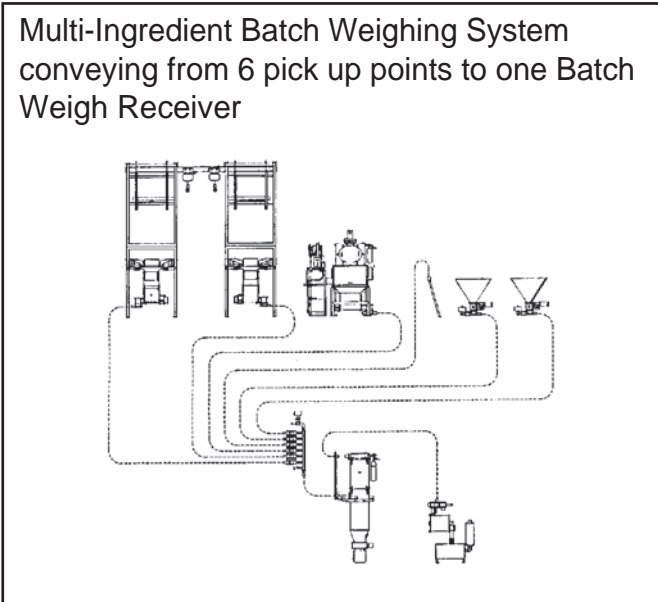
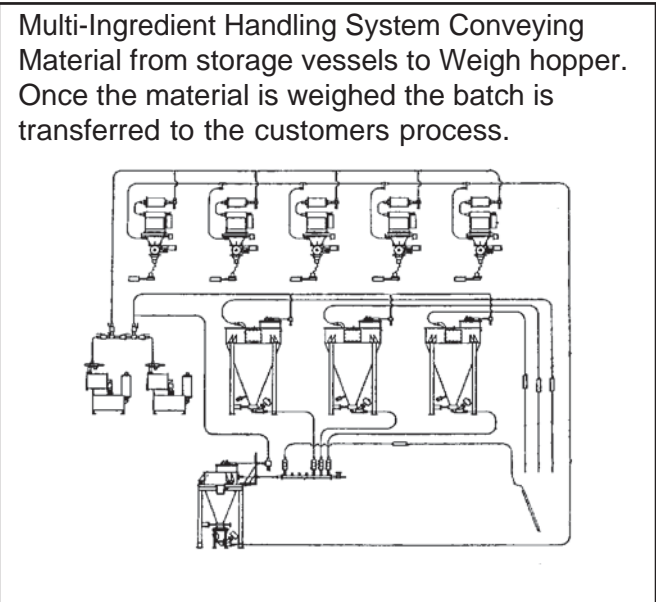
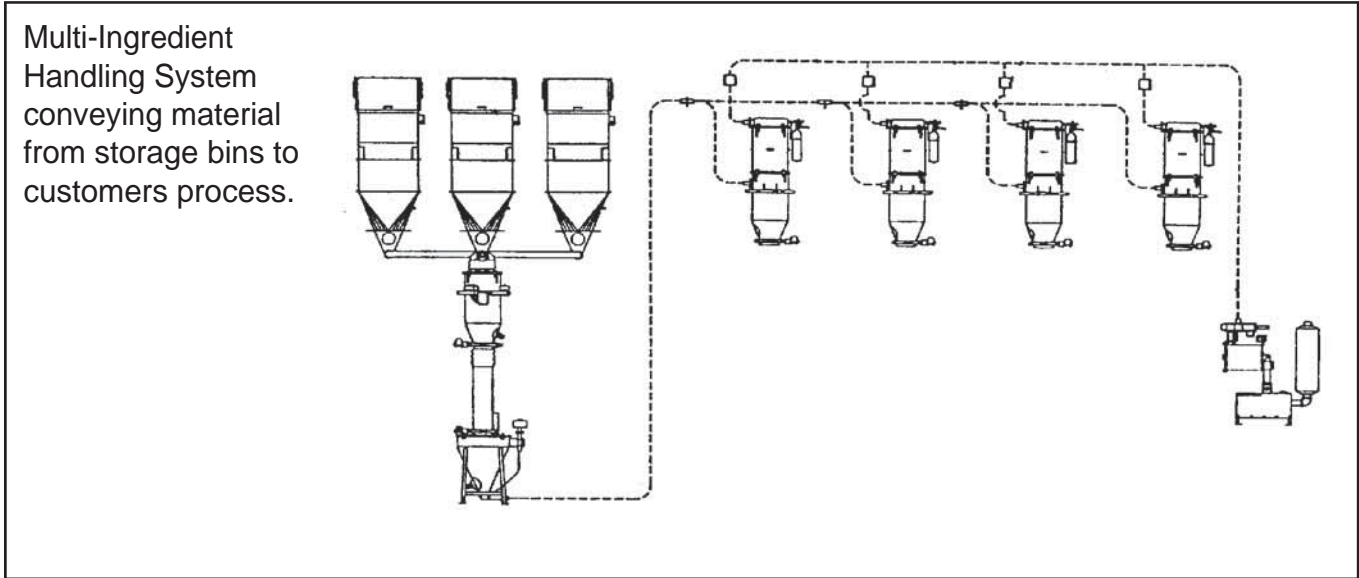

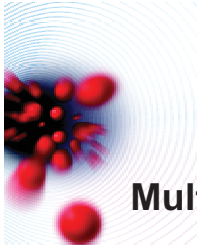

Multi-Ingredient Handling Systems

Multi-Ingredient Handling System transferring material to customers process via a VAC-U-MAX Batch Weigh Hopper.

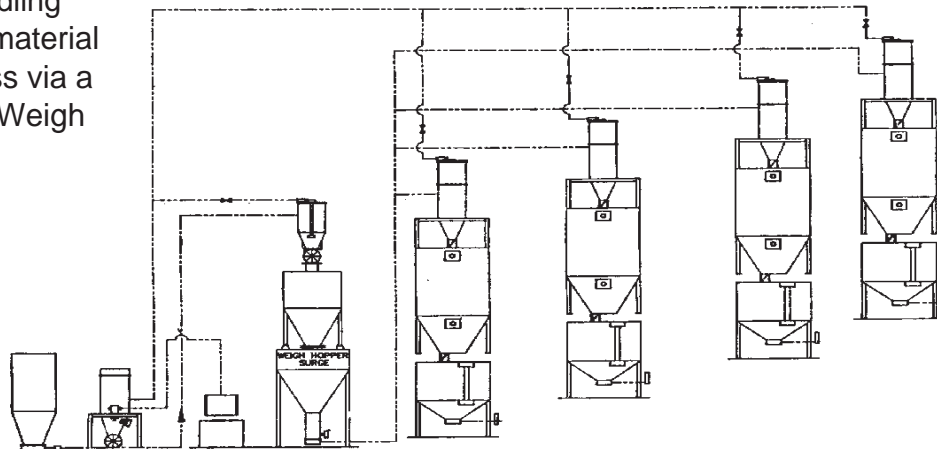

Multi-Ingredient Handling System Conveying Material to Batch Weigh Vacuum Receivers. Material is metered from Bulk Bag Unloader and directed to vacuum receiver with Flex Tube Diverter Valve.

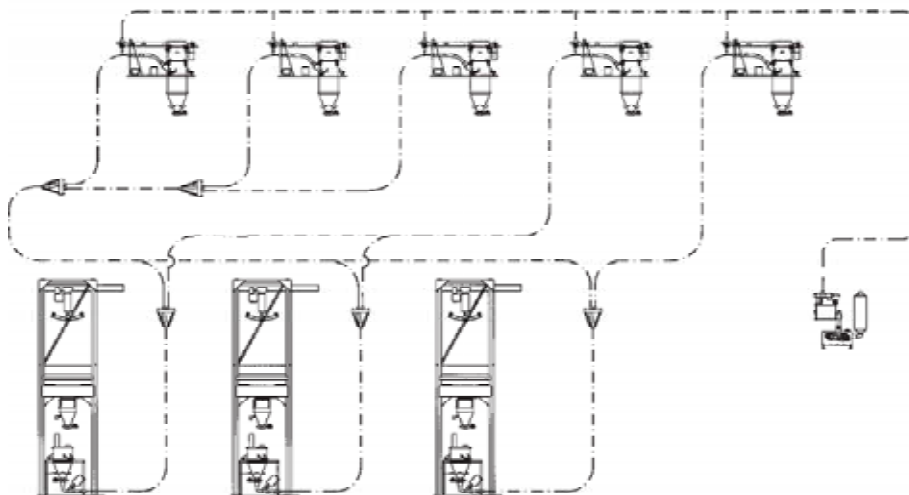

Single VAC-U-MAX Bulk Bag Unloader conveying material to multiple vacuum receivers. Filter separator straddles convey to meter carry over back into process.

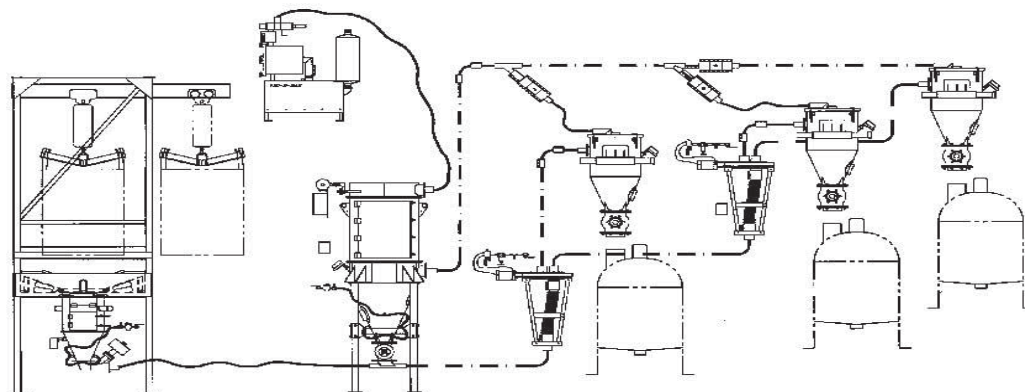

Multi-Ingredient Handling Systems

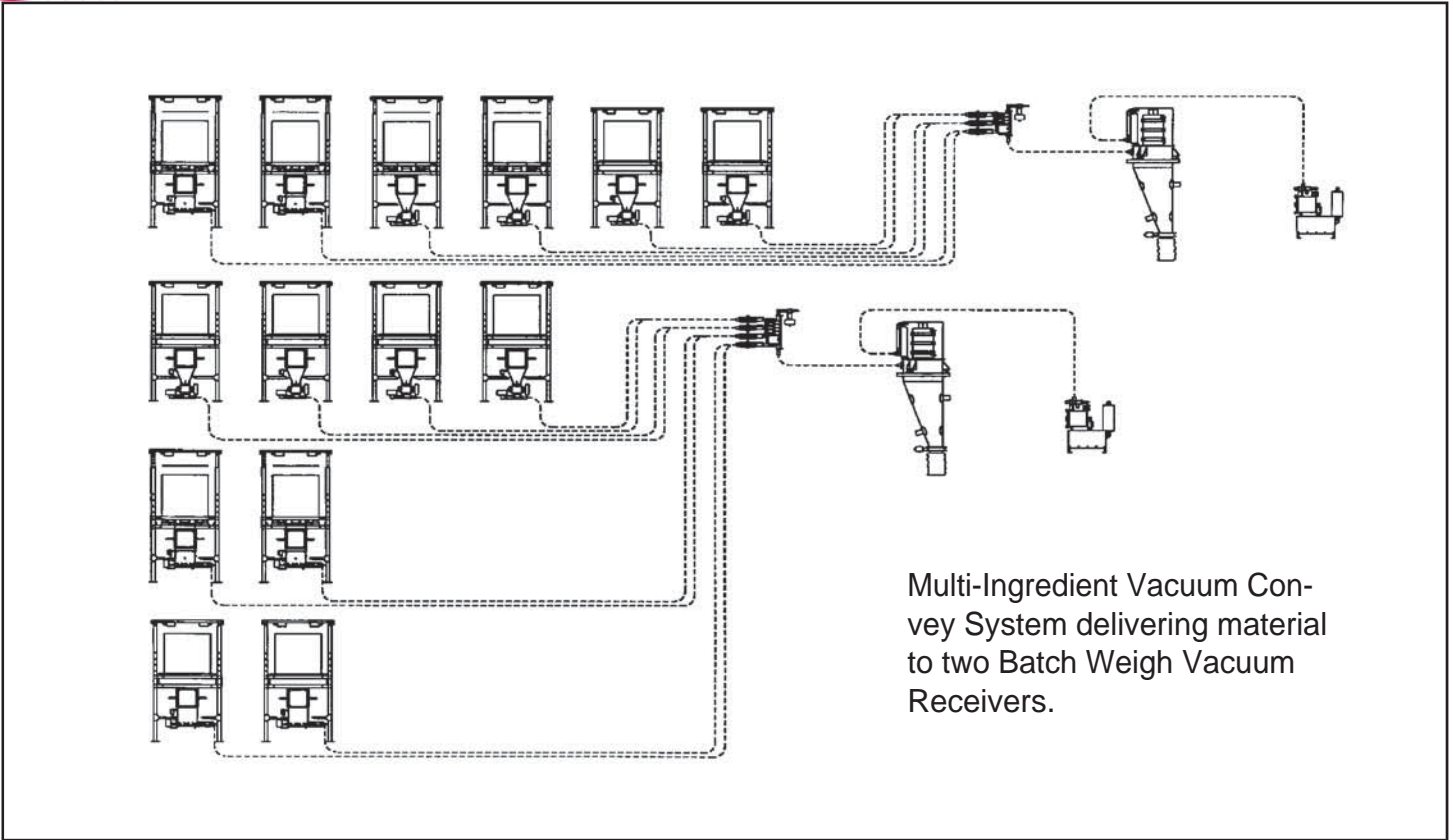

P & G Oxnard, CA



Sabormex, Puebla Mexico

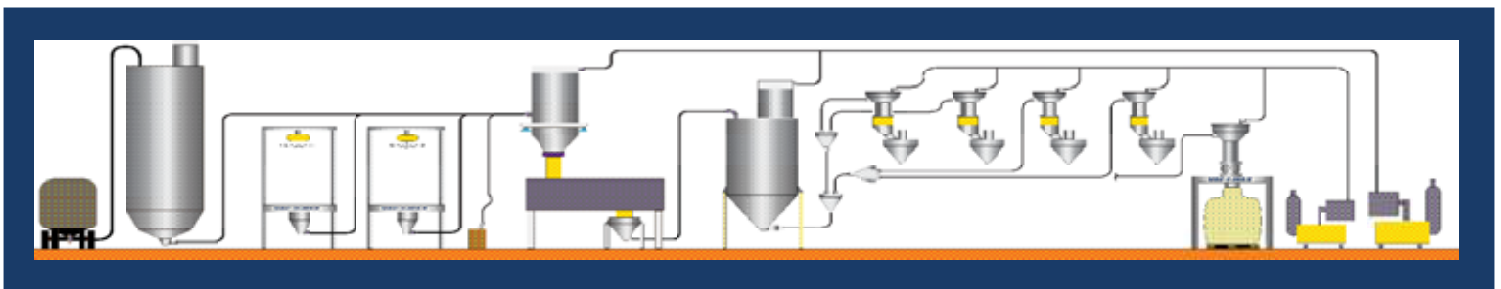

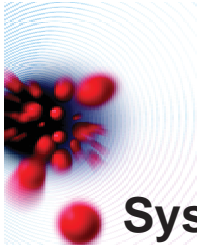

System Components:

Pick Up Points



Feedbins



Bulk Bag Unloaders



Bag Dump Stations



Bag Compactors

Material/Vacuum Receivers



*"Mini" Hopper
6" Diameter*



"Tube" Hoppers



*70 Degree Conical
Receivers*



Large Capacity Vessels



*USDA and Pharmaceutical
Grade Receivers*

Vacuum Producers

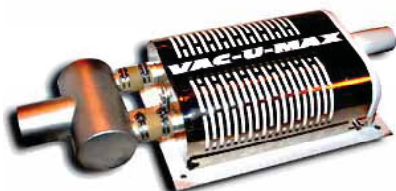

*Venturi Power Units,
Single and Double*



Regen Blower Packages



*Positive Displacement
Vacuum Pump Packages*

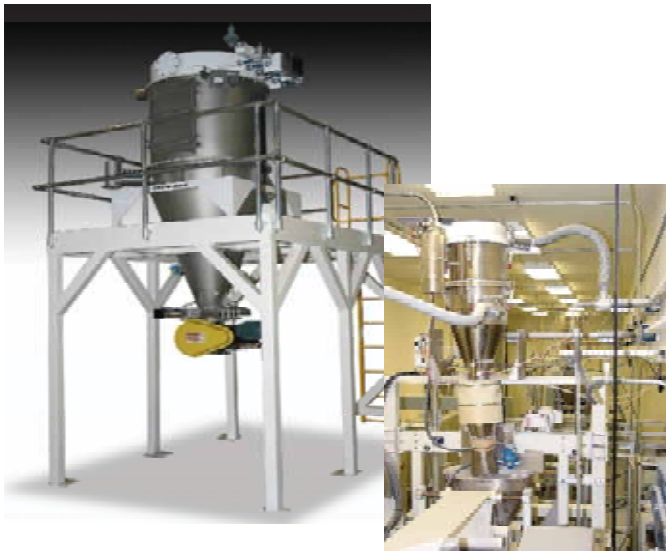

Pneumatic Conveying Systems

Pneumatic Conveying Systems from VAC-U-MAX. VAC-U-MAX is a premier manufacturer of custom pneumatic systems and support equipment for conveying, batching, and weighing materials. With a VAC-U-MAX system on site, your company's product can move gently and quickly from point to point, with nothing in the way to impede the efficiency of its movement.



Industrial Vacuum Cleaning Systems & Equipment

Industrial Cleaning Systems from VAC-U-MAX. VAC-U-MAX is a premier manufacturer of industrial vacuum cleaning systems for production lines and other dust-intensive areas. With a VAC-U-MAX heavy-duty vacuum cleaning system on site, both your capital equipment and your employees will be safer and cleaner. So put our field-proven equipment to work for you, and watch dust and other particulate contamination simply disappear.



Aerocon Aero-Mechanical Conveyors & Aero-Flex Flexible Screw Conveyors

Aero-Conveying is best defined as the movement of material using the desirable features of both pneumatic and mechanical conveying, and eliminating most of the disadvantages. The result is high volume, controlled transfer of dry materials (such as foods, pharmaceuticals, and chemical products), efficiently and economically, with little, if any, effect on the material, however friable and degradable.

VAC-U-MAX

69 William St
Belleville, NJ 07109
800-VAC-U-MAX * 973-759-4600 Fax: 973-759-6449
e-mail: info@vac-u-max.com www.vac-u-max.com

Represented By: