

Bulk Bag Unloading Systems MAXimized.

SINGLE SOURCE
CUSTOM ENGINEERING
APPLICATION EXPERTISE

VAC-U-MAX

DELIVERING MORE

GLOBAL SERVICE & SUPPORT
100% GUARANTEED
SINCE 1954

Bulk Bag Unloading Configurations

Efficiency Meets Productivity. Guaranteed.

VAC-U-MAX revolutionizes bulk bag unloading! MAXimize your bulk material handling with an easier, cleaner & more efficient way to discharge the contents of bulk & semi-bulk bags, even with material that is less than free flowing!

VAC-U-MAX Bulk Bag Unload Systems, also known as Bulk Bag Discharge Systems, are specifically designed to provide an easy, clean and efficient way to discharge the entire contents of bulk and semi-bulk bags, especially when the material is less than free flowing. A wide variety of features, benefits, and discharge options are available based on the applications specific parameters.

HOW IT WORKS

VAC-U-MAX Bulk Bag Unloading Systems feature heavy-duty welded tubular frames.

Bulk Bags can be loaded into the systems via:

- Hoist with motorized trolley
- Fork-lift and VAC-U-MAX lifting frame
- Utilizing existing hoist and I-Beam eliminating the upper frame

VAC-U-MAX Activator™ promotes the discharge of non-free-flowing materials by massaging the bottom of the bag with four paddles around the discharge spout. Automatic mode uses a level control below the bulk bag to start/stop the massage paddles. Manual mode overrides the level control.

Discharge options include:

- Pick-Up Adapter connected to the vacuum conveying system
- Screw Discharger for non-free flowing material or loss-in-weight feeding, or rotary air lock for applications requiring higher convey rates or controlled feeding
- Feed-bins and surge hoppers with single or multiple outlets, capacities from 2ft³ (60L) to 50ft³ (1.4m³), for vacuum, flexible screw or aero-mechanical conveying
- Lump-breakers for agglomerated chunks of material

FEATURES, BENEFITS & SYSTEM COMPONENTS:

- Heavy-Duty Welded Square-Tube Frame
- Optional Massage Paddles Maximize Flow Promotion
- General Purpose or XP UL-Certified Controls
- Many Bag Size & Bag Handling Options
- Iris Valve & Partial Bag Cutoff Options
- Discharge Options: Pick-Up Adapter, Screw Discharger, Rotary Airlock, Feed Bins and Lump Breakers
- Easy Access Door to Untie Bag Spout
- Optional Glove Box
- Optional upper frame with motorized hoist, remote pendant, for bulk bags from 36" (900mm) to 72" (1800mm) tall
- Standard Low-profile Bag-Lift X-Frame Saves 12" (300mm) of height

THE VAC-U-MAX DISTINCTION:

- Faster processing time
- USDA designs & materials of construction
- Easy, quick-clean & take-apart features
- Minimal footprint
- Made in the USA
- Local product support
- Performance guarantee
- Maximize regulatory compliance including (FSMA) sanitation and OSHA (Walking/Working Surfaces)
- Custom-engineering to meet overhead restrictions and/or custom bag sizes

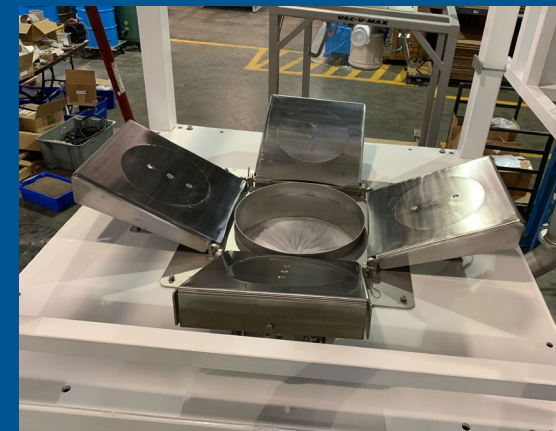

PHOTO: The VAC-U-MAX "Activator™" version features "No Maintenance" pneumatic actuated massage paddles that use 50% less compressed air, and eliminate rods & seals. Massage paddles apply force to 4 bottom edges instead of 2 sides, maximizing bulk material flow promotion of even the most difficult materials.



VARIOUS DISCHARGE OPTIONS



Call (800) VAC-U-MAX or visit vac-u-max.com and MAXimize your process!

BASIC CONFIGURATIONS



Basic Bulk Bag Unloader

- Bag lifting and stabilizing provided by customer
- Stainless Steel product contact areas
- Carbon steel or stainless steel frame



Forklift Frame Bulk Bag Unloader

*Highlighted in Yellow

- Bag lift-frame placed by forklift
- Spring-loaded bag extension
- Stainless steel product contact areas
- Carbon steel or stainless steel frame

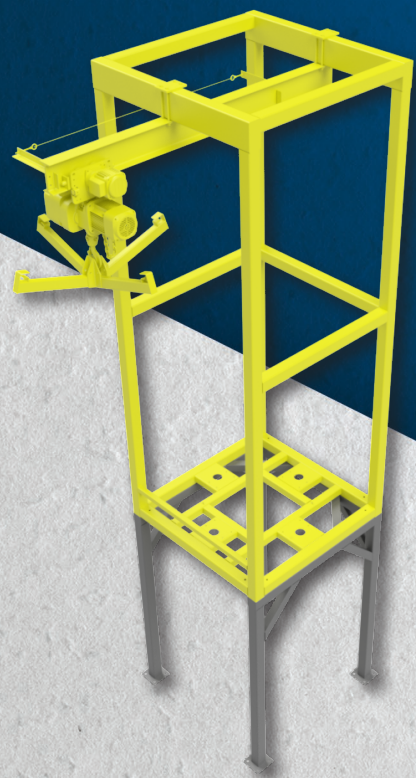

Upper Frame & Hoist Bulk Bag Unloader

*Highlighted in Yellow

- Self-contained bag lifting and placement
- I-Beam with hoist and operator pendant
- Engineered for 4,000 lbs (1820 kg) lift
- No forklift required
- Stainless steel product contact
- Carbon steel or stainless steel frame

OPTIONAL FEATURES

Fugitive Dust Collector

*Highlighted in Yellow

- Reduces operator exposure to dust during bag changes
- Pulse-jet filter cleaning & controls
- Collected dust returned to process

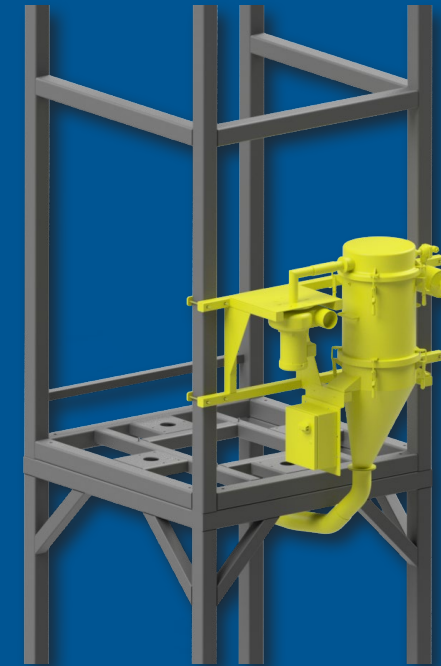

Activator™ Bag Massagers

*Highlighted in Yellow

- (4) Pneumatic paddles contact all bottom sides of bulk bag to promote maximum powder flow
- Massaging program alternates opposing pair of paddles in sequence

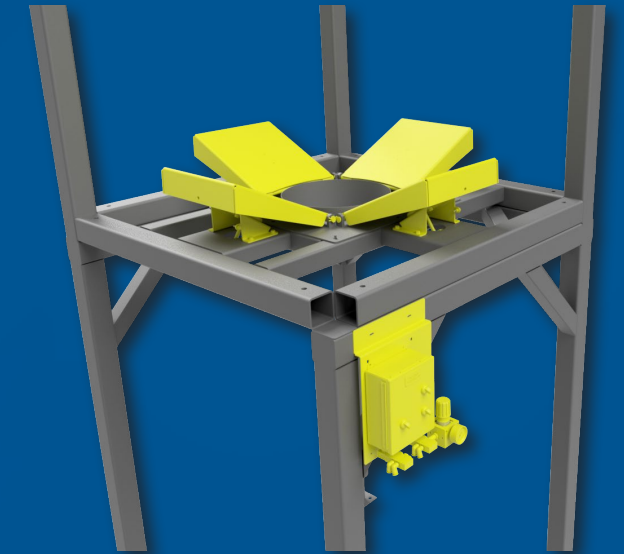

Iris Valve Bag Cutoff

*Highlighted in Yellow

- Manual Open / Close
- Tie / Untie bag spouts easily
- Wide operator access door

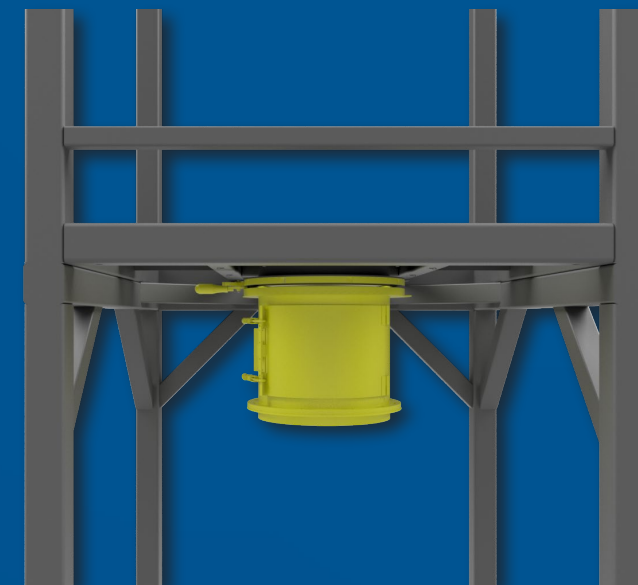

Surge Bin

*Highlighted in Yellow

- High throughput with one bulk bag on stand-by for unloading

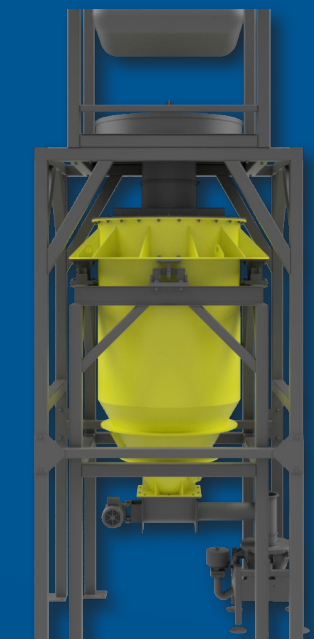

OPTIONAL FEATURES

Loss-in-Weight Frame

*Highlighted in Yellow

- Split-frame design takes load cells off the floor
- Rotary valve or screw discharger meters the material

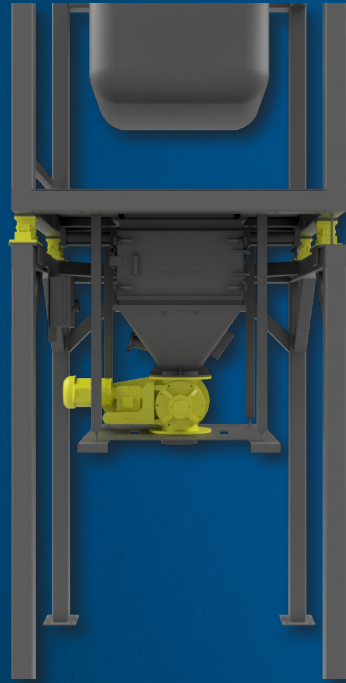

Partial-Bag Cutoff

*Highlighted in Yellow

- All-pneumatic squeezer bars and controls
- Large-operator access door with lockout of stored energy when open
- Maximum closure force for heavy powders

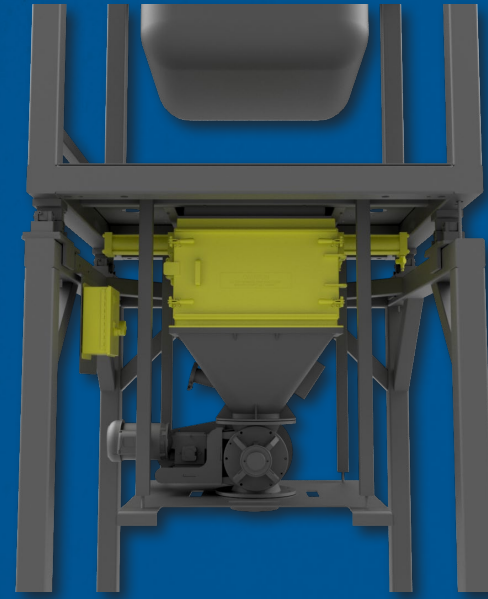

Integral Bag Dump Station

*Highlighted in Yellow

- Bulk bag for major ingredients and manual bags for minor ingredients

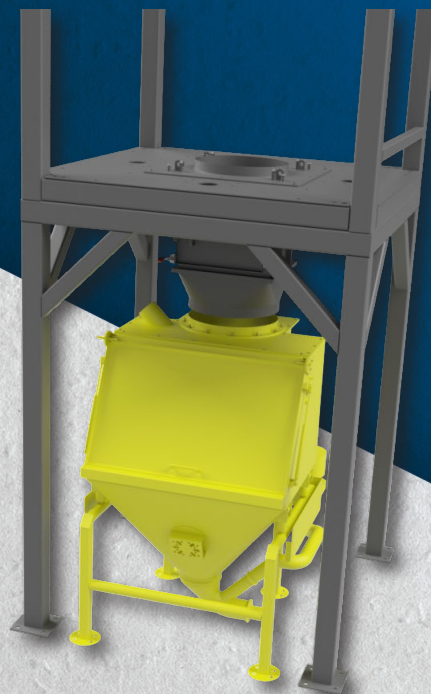

Stainless Steel Construction

*Highlighted in Yellow

- Bead blast or polished surfaces
- 304SS or 316SS



OPTIONAL FEATURES

Screw Discharger

*Highlighted in Yellow

- Controlled discharge of stubborn or fluidized powder into convey line
- For convey distances over 100ft (30m)

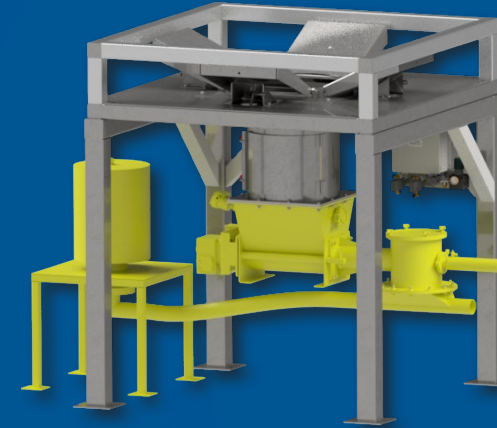

Bulk Bag Slitter

*Highlighted in Yellow

- Opens single-use bulk bags of free-flowing materials

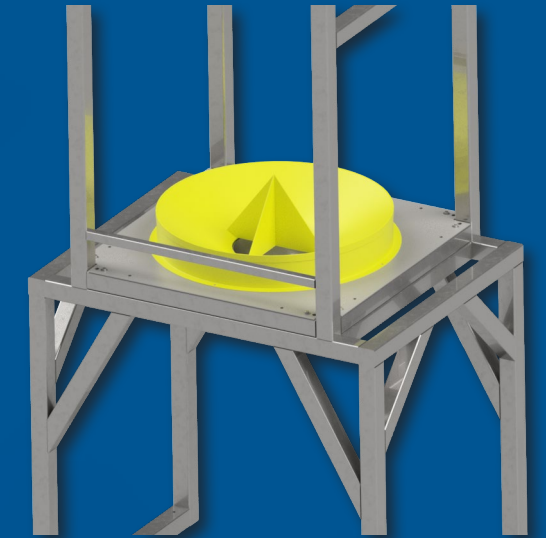

Other Options:

- Seismic designs with certification
- I-Beam and channel steel construction in lieu of square or round tubing
- Control enclosures: NEMA 4 (standard), NEMA 4X (304SS or 316SS) or NEMA 7/9
- Lump-breakers
- Clean-in-Place adapters for product contact surfaces
- Heavy-duty casters for empty-frame portability (basic or forklift designs only)
- Custom colors for carbon steel construction surfaces
- Custom hoist specifications

Bulk Bag Dims: *Need to Know*

- Weight of full bag
- Height of bag
- Length of bag
- Width of bag
- Strap Length
- Full Bag Stretched Height

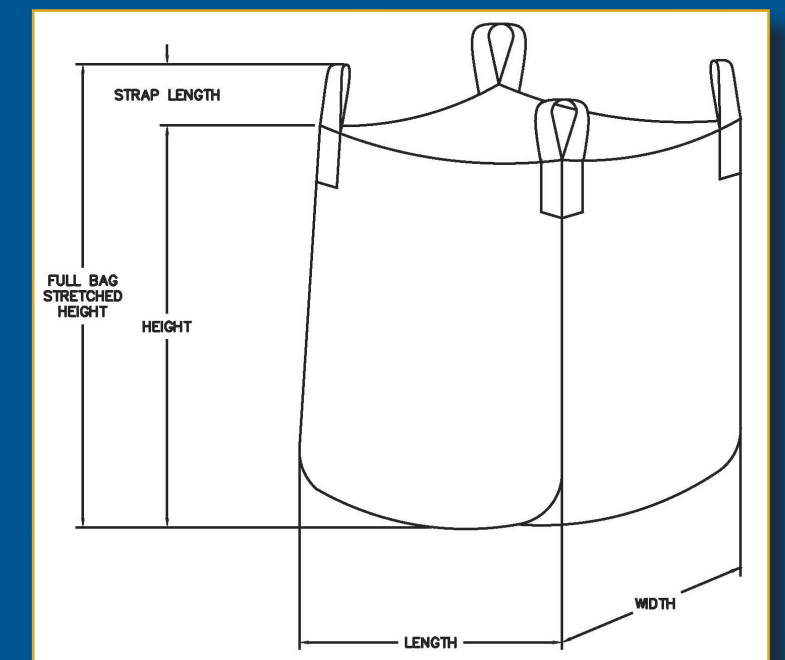

Call (800) VAC-U-MAX or visit vac-u-max.com and MAXimize your process!

OVER 65 YEARS OF GETTING IT RIGHT.

In material handling solutions, every detail is critical. So when you do business with VAC-U-MAX, you're guaranteed a lot more than a high-performing product: Pioneering materials handling technology. Custom engineering expertise. Rapid turnaround and responsive support. And of course, our 100% satisfaction guarantee.

For more than six decades, we've made a name as a single-source, dedicated provider, handling more types of materials, serving more markets, and offering the highest possible degree of customization—so your systems are maximized to fit your needs.



Standard Pick-Up Adapter on a BBU



Screw Discharger



Feedbin with multiple outlets



Rotary Valve Discharge on a BBU



SINGLE SOURCE
CUSTOM ENGINEERING
APPLICATION EXPERTISE

VAC-U-MAX

DELIVERING MORE

GLOBAL SERVICE & SUPPORT
100% GUARANTEED
SINCE 1954